

DV150X0M-N10

Product Specification

Rev.0



FUZHOU BOE OPTOELECTRONICS TECHNOLOGY Co.,LTD

REVISION HISTORY

() Preliminary specification

(√) Final specification

Rev.	Page	Description of changes	Date	Prepared
P0	P33/P34	Update Mechanical Content	2022.10.20	Wang Lulu
P1	P22	Update Quality Content	2023.1.3	Yang Danqin
	P5	Update Power Consumption	2023.1.3	Zhu Mingcheng
	P7	Update Power Consumption	2023.1.3	Zhu Mingcheng
	P23/P24	Update Package Content	2023.1.3	Zhu Mingcheng
P2	P21	Correct Mask Parameter	2023.1.9	Fang Xin
0	P4	Delete the appendices of clause 7*24	2023.1.18	ALL
	P5	Add Remarks: Number of LED Bar	2023.1.18	Zhu Mingcheng
	P5	Add Note 1	2023.1.18	ALL
	P6	Add Note 2	2023.1.18	ALL
	P18	Center Luminance of White: Add Optical Equipment	2023.1.18	Chen Guangquan
	P21	Add Test Condition: VIB、Shock	2023.1.18	Chen Guangquan
	P28	Delete the description about extreme scenarios	2023.1.18	Bao Fengqing
	ALL	Add Spec No	2023.1.18	Li You
	P23	Packing Order: Add Note	2023.1.18	Zhu Mingcheng
	P24	Add Note	2023.1.18	Zhu Mingcheng
	P25	Update Packing Note	2023.1.18	Zhu Mingcheng
	P34	Update APPENDIX	2023.1.18	Zhu Mingcheng
	P22	Update MDL ID Label	2023.6.29	Li You
	P25	Update Box Label	2023.6.29	Li You

Contents

No	ITEM	Page
	REVISIONS HISTORY	2
	CONTENTS	3
1	GENERAL DESCRIPTION	4
	1.1 Introduction	
	1.2 Features	
	1.3 Applications	
	1.4 General Specification	
2	ABSOLUTE MAXIMUM RATINGS	6
3	ELECTRICAL SPECIFICATIONS	7
	3.1 TFT LCD Open Cell	
	3.2 Backlight Unit	
4	INTERFACE CONNECTION	9
	4.1 Open Cell Input Signal & Power	
	4.2 LVDS Interface	
	4.3 LVDS Rx Interface Timing Parameter	
	4.4 LVDS Rx Interface Eye Diagram	
	4.5 LVDS Receiver Differential Input	
5	SIGNAL TIMING SPECIFICATIONS	13
	5.1 Timing Parameters (DE only mode)	
	5.2 Signal Timing Waveform	
	5.3 Input Signals, Basic Display Colors and Gray Scale of Colors	
	5.4 Power Sequence	
6	OPTICAL SPECIFICATIONS	18
7	MECHANICAL CHARACTERISTICS	20
8	RELIABILITY TEST	21
9	PRODCUT SERIAL NUMBER	22
10	PACKING INFORMATION	23
11	PRECAUTIONS	25
12	APPENDIX	30

1.0 GENERAL DESCRIPTION

1.1 Introduction

DV150X0M-N10 is a color active matrix TFT LCD MDL using amorphous silicon TFT's (Thin Film Transistors) as an active switching devices. This MDL has a 15 inch diagonally measured active area with XGA resolutions (1024 horizontal by 768 vertical pixel array). Each pixel is divided into RED, GREEN, BLUE dots which are arranged in vertical stripe and this module can display 16.7M colors. The TFT-LCD MDL panel is adapted for a low reflection and higher color type.

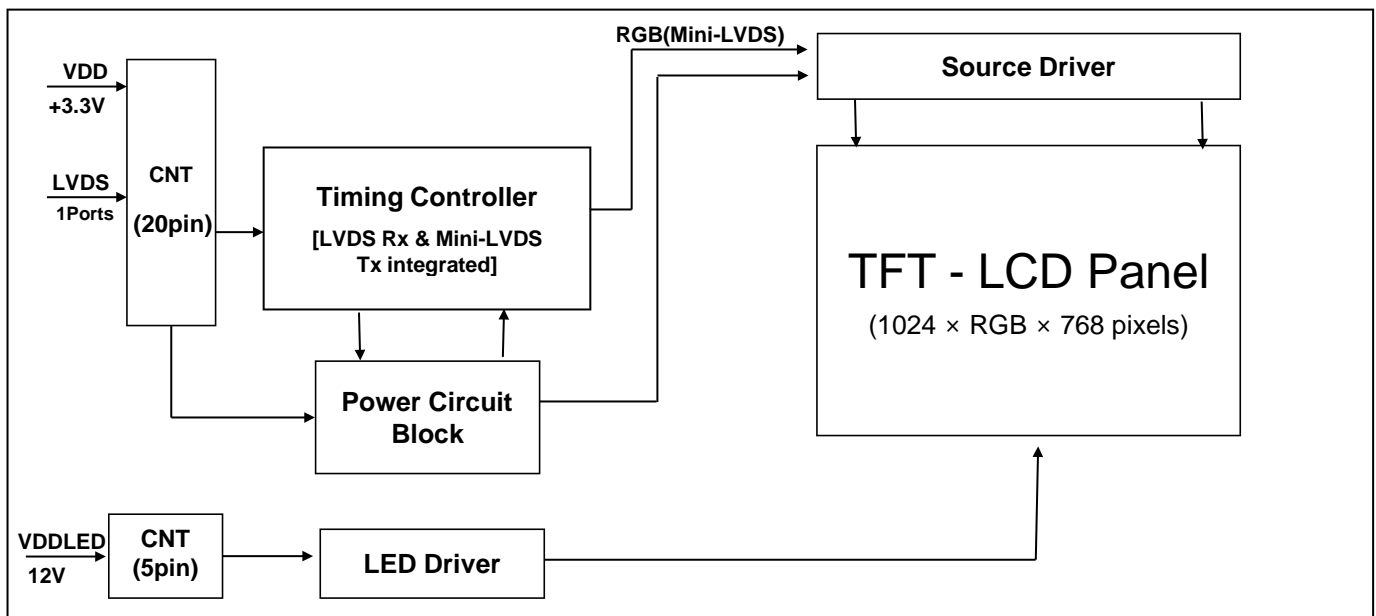

1.2 Features

- LVDS interface with 1 pixel / clock
- High-speed response
- Low color shift image quality
- 6-bit +FRC color depth, display 16.7M colors
- Wide viewing angle
- DE (Data Enable) only mode
- ADS technology is applied for high display quality
- RoHS compliant
- 7*24hrs usage support

1.3 Application

- Display Terminals for Control System
- Landscape and Portrait Display
- Mainly Applies to Game Consoles

1.4 General Specification

< Table 1. General Specifications >

Parameter	Specification	Unit	Remarks
Active area	304.128(H) × 228.096(V)	mm	
Number of pixels	1024(H) × 768(V)	pixels	
Pixel pitch	0.297(H) × 0.297(V)	mm	
Pixel arrangement	Pixels RGB Vertical stripe		
Display colors	16.7M	colors	6bits+FRC
Display mode	Normally Black		
Dimensional outline	326.5(H)×253.5(V)×9.7(Typ.)	mm	Detail refer to drawing
Weight	930	g	
Power Consumption	10.8	Watt	Typ.
Bezel width (L/R/U/D)	10/10/11.7/11.7	mm	
Surface Treatment	Haze 25%, 3H		
Back-light	E-LED Light bar Type		48ea LED/BLU
LED life	50000	hrs	
Display Direction	landscape & Portrait		

2.0 ABSOLUTE MAXIMUM RATINGS

The followings are maximum values which, if exceed, may cause faulty operation or damage to the unit. The operational and non-operational maximum voltage and current values are listed in Table 2.

< Table 2. Open Cell Electrical Specifications >

[VSS=GND=0V]

Parameter	Symbol	Min.	Max.	Unit	Remark
Power Supply Voltage	VDD	-0.3	4	V	Ta = 25 °C
Operating Temperature	T _{OP}	-20	+70	°C	Note 1 Note 2
Storage Temperature	T _{SUR}	-20	+70	°C	
	T _{ST}	-20	+70	°C	
Operating Ambient Humidity	Hop	10	90	%RH	
Storage Humidity	Hst	10	90	%RH	

Note 1 : Temperature and relative humidity range are shown in the figure below.

Wet bulb temperature should be 39 °C max. and no condensation of water.

Note 2 : When used near the limit conditions of temperature and humidity, the life will be reduced.

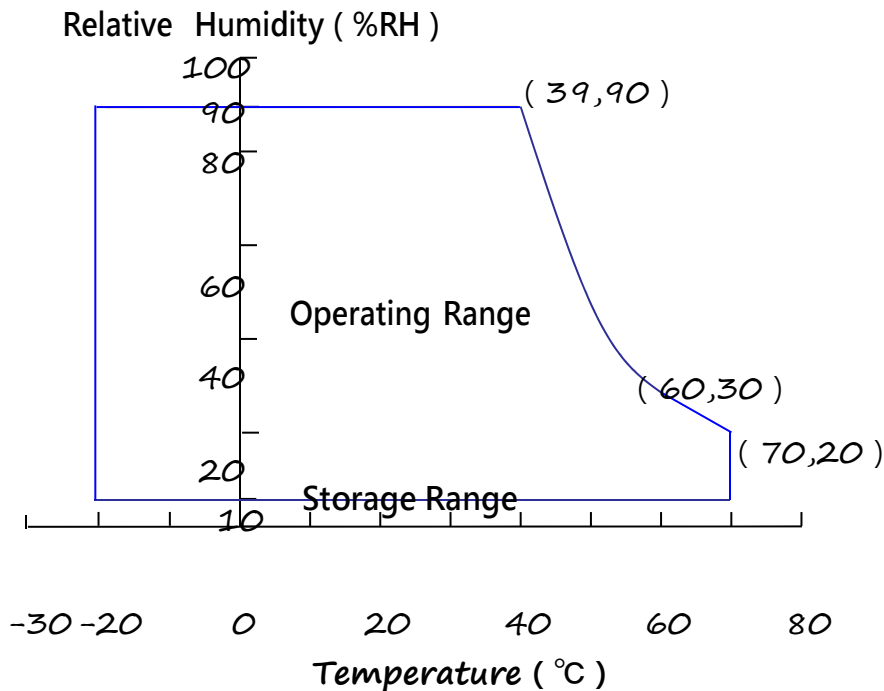

3.0 ELECTRICAL SPECIFICATIONS

3.1 TFT LCD Open Cell

< Table 3. Open Cell Electrical Specifications >

[Ta =25±2 °C]

Parameter	Symbol	Values			Unit	Remark	
		Min	Typ	Max			
Power Supply Input Voltage	VDD	3.0	3.3	3.6	V	Note 1	
Power Supply Current	IDD	-	455	900	mA		
Power Supply Ripple Voltage	VRP	-	-	300	mV		
Rush Current	IRUSH	-	2	3	A	Note 2	
LVDS Interface	Differential Input High Threshold Voltage	VLVTH	-	-	+100	mV	VLVC=1.2V
	Differential Input Low Threshold Voltage	VLVTL	-100	-	-	mV	
	Common Input Voltage	VLVC	0.7	-	1.6	V	
CMOS Interface	Input High Threshold Voltage	VIH	0.7VDD	-	VDD	V	
	Input Low Threshold Voltage	VIL	0	-	0.3VDD	V	
Power Consumption	PD		1.5	3	W		
	PBL		9.3	10.2		Note 3	
	Ptotal		10.8	13.2			

Note 1 : The supply voltage is measured and specified at the interface connector of LCM.

The current draw and power consumption specified is for VDD=3.3V,

Test Pattern of power supply current

a) Typ : Mosaic 7X5 (L0/L255)

b) Max : Vline Subline (L255))

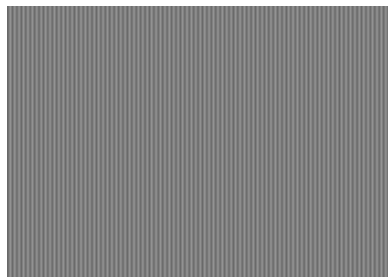
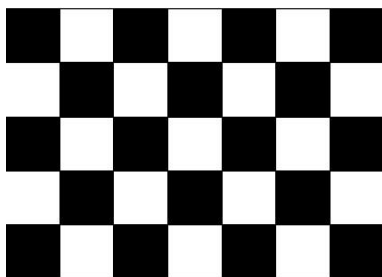

Note 2 : The duration of rush current is about 2ms and rising time of Power Input is 1ms(min)

Note 3 : Calculated value for reference (Input pins*VPIN ×IPIN) excluding inverter loss.

3.0 ELECTRICAL SPECIFICATIONS

3.2 Backlight Unit

< Table 4. Backlight Unit Electrical Specifications >

[Ta =25±2 °C]

Parameter		Min.	Typ.	Max.	Unit	Remarks	
LED Driver Power Supply Voltage		H_{VDD}	10.8	12	12.6	V	
LED Driver Power Supply Current		I_{HVDD}	600	775	850	mA	
EN Control Level	Backlight on	V_{ENH}	3	3.3	3.6	V	EN logic high voltage
	Backlight off	V_{ENL}	0	0	0.6	V	EN logic low voltage
PWM Control Level	PWM High Level	V_{PML}	3	3.3	3.6	V	
	PWM Low Level	V_{PML}	0	0	0.6	V	
PWM Control Frequency		F_{PWM}	0.12	-	20	KHz	Refer to customer comments
Duty Ratio		-	5	-	100	%	
LED Life-Time		N/A	50,000	-	-	Hour	Note4
LED Light Bar Input Voltage Per Input Pin		V_{PIN}	32.4	36	39.6	V	
LED Light Bar Input Current Per Input Pin		I_{PIN}	-	55	-	mA	Note2
LED Power Consumption		PBL	-	9.3	10.2	W	Note3

LED bar consists of 48LED packages,4 strings(parallel)*12packages(serial)

Note1: There are one light bar ,and the specified current is input LED chip 100% duty current

Note2: The sense current of each input pin is 55mA

Note3: $PBL=4 \text{ Input pins} \times V_{PIN} \times I_{PIN}$

Note4: The lifetime is determined as the time at which luminance of LED become 50% of the initial brightness or not normal lighting at $I_{PIN}=55\text{mA}$ on condition of continuous operating at $25 \pm 2 \text{ }^\circ\text{C}$

4.0 INTERFACE CONNECTION**4.1 Open Cell Input Signal & Power**

- LVDS Connector : MSB240420HEA or Compatible.

< Table 4. Open Cell Input Connector Pin Configuration >

Pin No	Symbol	Description	Pin No	Symbol	Description
1	VDD	Power Supply , 3.3V(typ.)	11	RIN2-	-LVDS differential data input 2
2	VDD	Power Supply,3.3V(typ.)	12	RIN2+	+LVDS differential data input 2
3	VSS	Ground	13	VSS	Ground
4	NC	No Connection	14	CLKIN-	-LVDS differential clock input CLK
5	RIN0-	-LVDS differential data input 0	15	CLKIN+	+LVDS differential clock input CLK
6	RIN0+	+LVDS differential data input 0	16	VSS	Ground
7	VSS	Ground	17	RIN3-	-LVDS differential data input 3
8	RIN1-	-LVDS differential data input 1	18	RIN3+	+LVDS differential data input 3
9	RIN1+	+LVDS differential data input 1	19	VSS	Ground
10	VSS	Ground	20	NC	No Connection

4.2 LED Light Bar

-LED connector : CI4205M1HR0-NH or Compatible

< Table 5. LED Light Bar >

Pin No	Symbol	Description
1	NC	No Connection
2	Dimming	PWM Dimming
3	Enable	3.3V-On / 0V-Off
4	GND	Ground
5	VCC	12V

- Notes : 1. NC(Not Connected) : This pins are only used for BOE internal operations.
 2. Input Level of LVDS signal is based on the EIA-644 Standard.

BIST Pattern

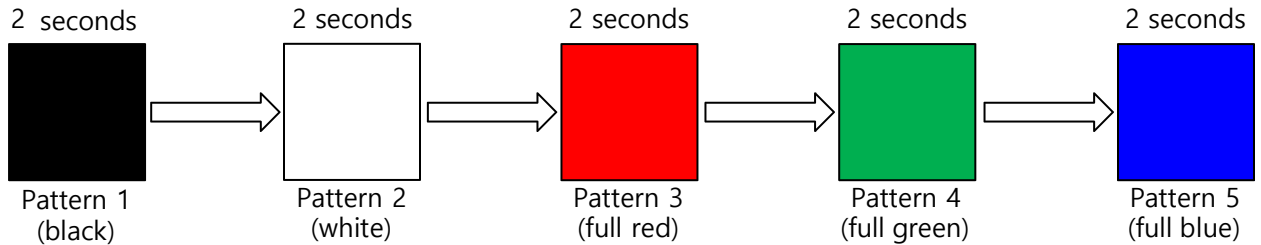

4.2 LVDS Interface

- LVDS Receiver : Timing Controller (LVDS Rx merged) / LVDS Data : Pixel Data

< Table 6. Open Cell Input Connector Pin Configuration >

	Input Signal	Transmitter		Interface		HT236F01-100 (CN 11)	Remark
		Pin No.	Pin No.	System (Tx)	TFT-LCD (Rx)	Pin No.	
LVDS	OR0	51	48 47	OUT0- OUT0+	RXO0- RXO0+	1	
	OR1	52					
	OR2	54					
	OR3	55					
	OR4	56					
	OR5	3					
	OG0	4	46 45	OUT1- OUT1+	RXO1- RXO1+	3	
	OG1	6					
	OG2	7					
	OG3	11					
	OG4	12					
	OG5	14					
	OB0	15	42 41	OUT2- OUT2+	RXO2- RXO2+	5	
	OB1	19					
	OB2	20					
	OB3	22					
	OB4	23					
	OB5	24					
	Hsync	27	40 39	CLK OUT- CLK OUT+	RXO CLK- RXO CLK+	8	
	Vsync	28					
DE	30						
MCLK	31	38 37	OUT3- OUT3+	RXO3- RXO3+	10		
OR6	50					11	
OR7	2						
OG6	8						
OG7	10						
OB6	16						
OB7	18						
RSVD	25						

4.3 LVDS Rx Interface Timing Parameter

The specification of the LVDS Rx interface timing parameter is shown in Table 6.

<Table 7. LVDS Rx Interface Timing Specification>

Item	Symbol	Min	Typ	Max	Unit	Remark
CLKIN Period	tRCIP	10.31	13.47	15.87	nsec	
Input Data 0	tRIP1	$0.5 \times tRCIP/7-0.4$	$0.5 \times tRCIP/7$	$0.5 \times tRCIP/7 + 0.4$	nsec	
Input Data 1	tRIP0	$1.5 \times tRCIP/7 - 0.4$	$1.5 \times tRCIP/7$	$1.5 \times tRCIP/7 + 0.4$	nsec	
Input Data 2	tRIP6	$2.5 \times tRCIP/7-0.4$	$2.5 \times tRCIP/7$	$2.5 \times tRCIP/7+0.4$	nsec	
Input Data 3	tRIP5	$3.5 \times tRCIP/7-0.4$	$3.5 \times tRCIP/7$	$3.5 \times tRCIP/7+0.4$	nsec	
Input Data 4	tRIP4	$4.5 \times tRCIP/7-0.4$	$4.5 \times tRCIP/7$	$4.5 \times tRCIP/7+0.4$	nsec	
Input Data 5	tRIP3	$5.5 \times tRCIP/7-0.4$	$5.5 \times tRCIP/7$	$5.5 \times tRCIP/7+0.4$	nsec	
Input Data 6	tRIP2	$6.5 \times tRCIP/7-0.4$	$6.5 \times tRCIP/7$	$6.5 \times tRCIP/7+0.4$	nsec	

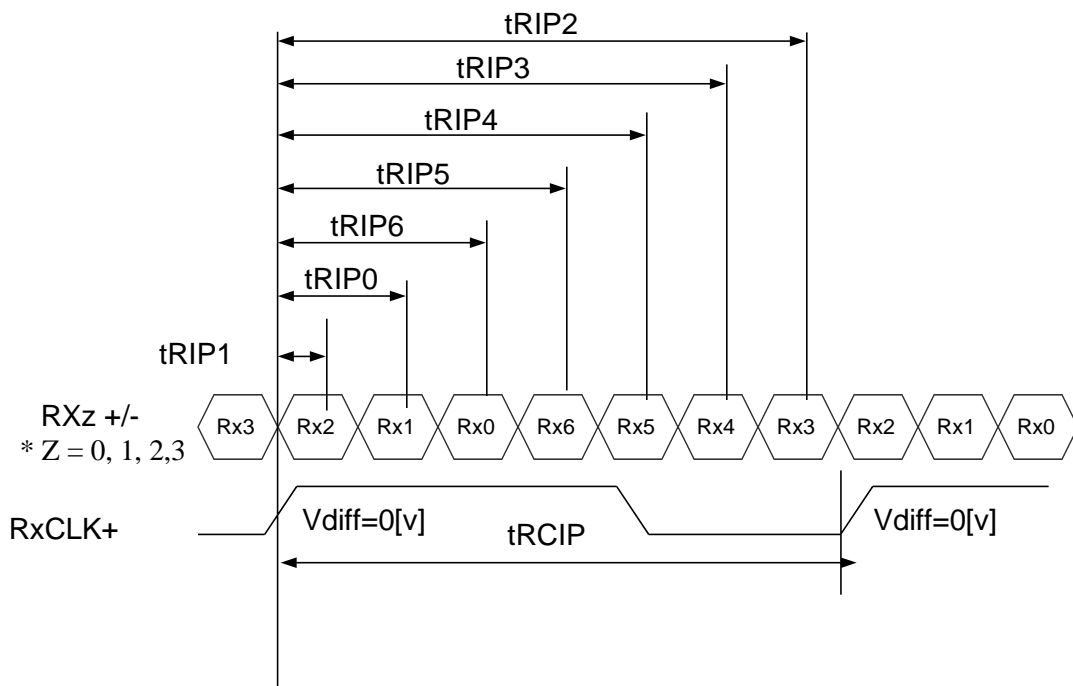

* $V_{diff} = (RXz+) - (RXz-), \dots, (RXCLK+) - (RXCLK-)$

5.0 SIGNAL TIMING SPECIFICATION**5.1 Timing Parameters (DE only mode)**

< Table 8. Timing Table >

Item		Symbols	Min	Typ	Max	Unit	
Clock	Frequency	1/Tc	52	58	71	MHz	
	High Time	Tch	-	4/7Tc	-		
	Low Time	Tcl	-	3/7Tc	-		
Frame Period		Tv	48	60	63	Hz	
Horizontal Active Display Term		Valid	t _{HV}	-	1024	-	t _{CLK}
		Total	t _{HP}	1200	1344	1400	t _{CLK}
Vertical Active Display Term		Valid	t _{VV}	-	768	-	t _{HP}
		Total	t _{VP}	788	806	845	t _{HP}

Notes: This product is DE only mode. The input of Hsync & Vsync signal does not have an effect on normal operation.

< Table 9. LVDS Input SSCG >

Symbol	Parameter	Condition	Min	Typ	Max	Unit
F	LVDS Input frequency	-	25	-	100	MHz
T _{LVSK}	LVDS channel to channel skew	F=58MHz V _{IC} =1.2V V _{ID} =±200mV	-600	-	+600	ps
F _{LVMOD}	Modulating frequency of input clock during SSC	F=58MHz V _{IC} =1.2V V _{ID} =±200mV	10	-	300	KHz
F _{LVDEV}	Maximum deviation of input clock frequency during SSC		-3	-	+3	%
T _{CY-CY}	Cycle to Cycle jitter		-	-	200	ps

5.2 Signal Timing Waveform

5.2.1 Sync Timing Waveform

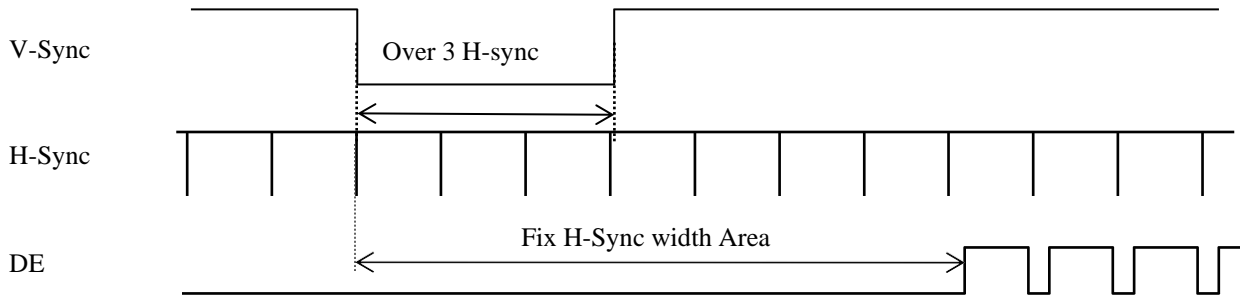

- 1) Need over 3 H-sync during V-Sync Low
- 2) Fix H-Sync width from V-Sync falling edge to first rising edge

5.2.2 Vertical Timing Waveform

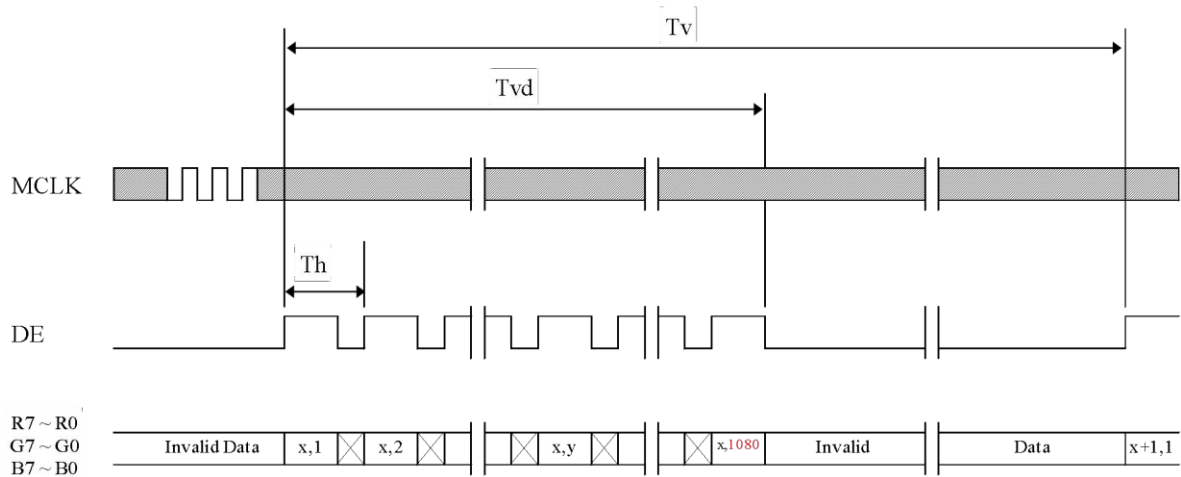

5.2.3 Horizontal Timing Waveform

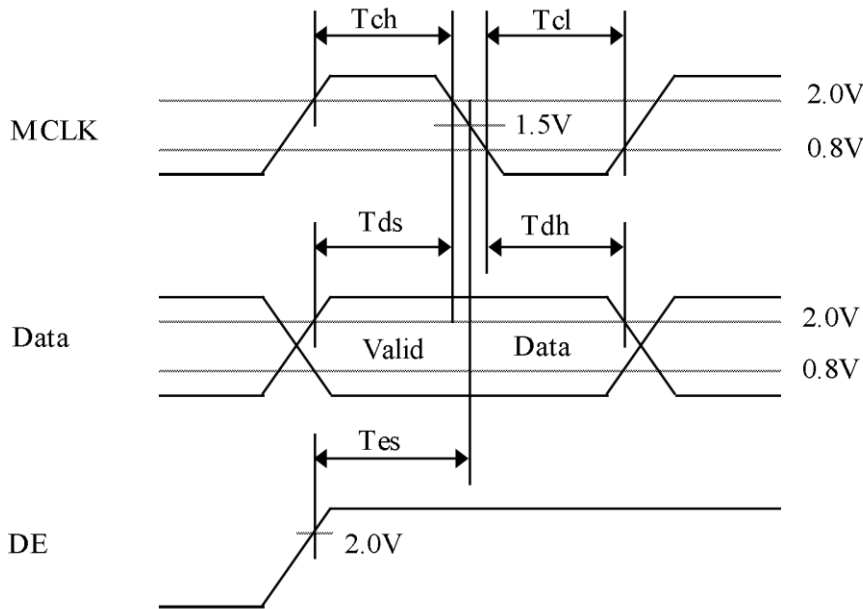
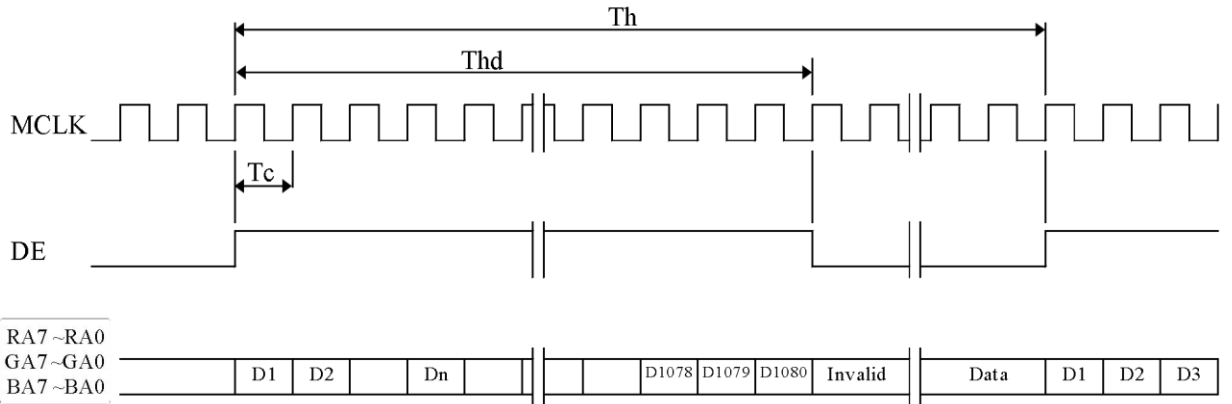

5.3 Input Signals, Basic Display Colors and Gray Scale of Colors

< Table 10. Input Signal and Display Color Table >

Color & Gray Scale		Input Data Signal																							
		Red Data								Green Data								Blue Data							
		R7	R6	R5	R4	R3	R2	R1	R0	G7	G6	G5	G4	G3	G2	G1	G0	B7	B6	B5	B4	B3	B2	B1	B0
Basic Colors	Black	0	0	0	0	0	0	0	0	0	0	0	0	0	0	0	0	0	0	0	0	0	0	0	
	Blue	0	0	0	0	0	0	0	0	0	0	0	0	0	0	0	0	1	1	1	1	1	1	1	1
	Green	0	0	0	0	0	0	0	0	1	1	1	1	1	1	1	1	0	0	0	0	0	0	0	0
	Cyan	0	0	0	0	0	0	0	0	1	1	1	1	1	1	1	1	1	1	1	1	1	1	1	1
	Red	1	1	1	1	1	1	1	1	0	0	0	0	0	0	0	0	0	0	0	0	0	0	0	0
	Magenta	1	1	1	1	1	1	1	1	0	0	0	0	0	0	0	0	0	1	1	1	1	1	1	1
	Yellow	1	1	1	1	1	1	1	1	1	1	1	1	1	1	1	1	0	0	0	0	0	0	0	0
	White	1	1	1	1	1	1	1	1	1	1	1	1	1	1	1	1	1	1	1	1	1	1	1	1
Gray Scale of Red	Black	0	0	0	0	0	0	0	0	0	0	0	0	0	0	0	0	0	0	0	0	0	0	0	
	△	0	0	0	0	0	0	0	1	0	0	0	0	0	0	0	0	0	0	0	0	0	0	0	
	Darker	0	0	0	0	0	0	1	0	0	0	0	0	0	0	0	0	0	0	0	0	0	0	0	
	△																								
	▽																								
	Brighter	1	1	1	1	1	1	0	1	0	0	0	0	0	0	0	0	0	0	0	0	0	0	0	0
	▽	1	1	1	1	1	1	1	0	0	0	0	0	0	0	0	0	0	0	0	0	0	0	0	0
	Red	1	1	1	1	1	1	1	1	0	0	0	0	0	0	0	0	0	0	0	0	0	0	0	0
Gray Scale of Green	Black	0	0	0	0	0	0	0	0	0	0	0	0	0	0	0	0	0	0	0	0	0	0	0	
	△	0	0	0	0	0	0	0	0	0	0	0	0	0	0	0	1	0	0	0	0	0	0	0	
	Darker	0	0	0	0	0	0	0	0	0	0	0	0	0	0	1	0	0	0	0	0	0	0	0	
	△																								
	▽																								
	Brighter	0	0	0	0	0	0	0	0	1	1	1	1	1	1	0	1	0	0	0	0	0	0	0	0
	▽	0	0	0	0	0	0	0	0	1	1	1	1	1	1	1	0	0	0	0	0	0	0	0	0
	Green	0	0	0	0	0	0	0	0	1	1	1	1	1	1	1	1	0	0	0	0	0	0	0	0
Gray Scale of Blue	Black	0	0	0	0	0	0	0	0	0	0	0	0	0	0	0	0	0	0	0	0	0	0	0	
	△	0	0	0	0	0	0	0	0	0	0	0	0	0	0	0	0	0	0	0	0	0	0	1	
	Darker	0	0	0	0	0	0	0	0	0	0	0	0	0	0	0	0	0	0	0	0	0	0	1	
	△																								
	▽																								
	Brighter	0	0	0	0	0	0	0	0	0	0	0	0	0	0	0	0	1	1	1	1	1	1	0	1
	▽	0	0	0	0	0	0	0	0	0	0	0	0	0	0	0	0	1	1	1	1	1	1	1	0
	Blue	0	0	0	0	0	0	0	0	0	0	0	0	0	0	0	0	1	1	1	1	1	1	1	1
Gray Scale of White	Black	0	0	0	0	0	0	0	0	0	0	0	0	0	0	0	0	0	0	0	0	0	0	0	
	△	0	0	0	0	0	0	1	0	0	0	0	0	0	0	0	1	0	0	0	0	0	0	1	
	Darker	0	0	0	0	0	0	1	0	0	0	0	0	0	0	1	0	0	0	0	0	0	0	1	
	△																								
	▽																								
	Brighter	1	1	1	1	1	1	0	1	1	1	1	1	1	0	1	1	1	1	1	1	1	1	0	1
	▽	1	1	1	1	1	1	1	0	1	1	1	1	1	1	0	1	1	1	1	1	1	1	1	0
	White	1	1	1	1	1	1	1	1	1	1	1	1	1	1	1	1	1	1	1	1	1	1	1	1

5.4 Power Sequence

To prevent a latch-up or DC operation of the LCD module, the power on/off sequence shall be as shown in below

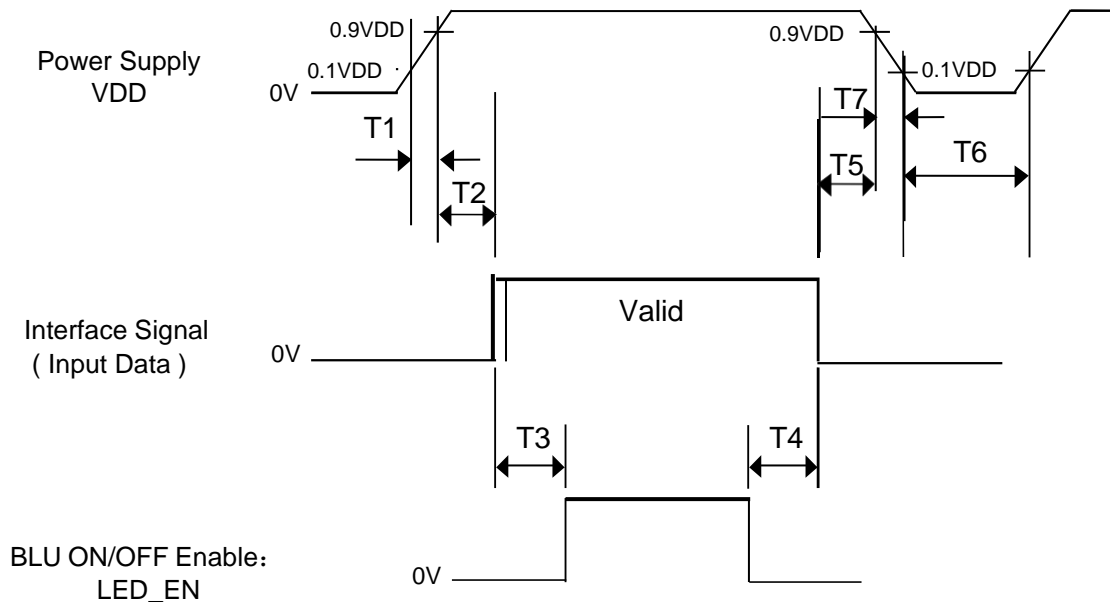

< Table 11. Sequence Table >

Parameter	Values			Units
	Min	Typ	Max	
T1	0.5	-	10	ms
T2	0	-	50	ms
T3	500	-	-	ms
T4	500	-	-	ms
T5	0	-	30	ms
T6	1	-	-	s

- Notes:
1. Back Light must be turn on after power for logic and interface signal are valid.
 2. Even though T1 is out of SPEC, it is still ok if the inrush current of VDD is below the limit.
 3. When $VDD < 0.9VDD(Typ.)$, Power off.
 4. T7 decreases smoothly, if there were rebounding voltage, it must smaller than 0.5 volts.

6.0 OPTICAL SPECIFICATIONS

The test of optical specifications shall be measured in a dark room (ambient luminance \leq 1 lux and temperature $=25\pm 2^{\circ}\text{C}$) with the equipment of Luminance meter system (Goniometer system and PR788) and test unit shall be located at an approximate distance 180cm from the LCD surface at a viewing angle of θ and Φ equal to 0° . We refer to $\theta_{\Phi=0}$ ($=\theta_3$) as the 3 o'clock direction (the "right"), $\theta_{\Phi=90}$ ($=\theta_{12}$) as the 12 o'clock direction ("upward"), $\theta_{\Phi=180}$ ($=\theta_9$) as the 9 o'clock direction ("left") and $\theta_{\Phi=270}$ ($=\theta_6$) as the 6 o'clock direction ("bottom"). While scanning θ and/or Φ , the center of the measuring spot on the Display surface shall stay fixed. The measurement shall be executed after 30 minutes warm-up period. VDD shall be 12.0V at 25°C . Optimum viewing angle direction is 6 'clock.

< Table 12. Optical Table >

[VDD = 5.0V, Frame rate = 60Hz, Ta = $25\pm 2^{\circ}\text{C}$]

Parameter		Symbol	Condition	Min	Typ	Max	Unit	Remark
Viewing Angle	Horizontal	Θ_3	CR > 10	85	89		Deg.	Note 1
		Θ_9		85	89		Deg.	
	Vertical	Θ_{12}		85	89		Deg.	
		Θ_6		85	89		Deg.	
Center Luminance of White		Lc	$\Theta = 0^{\circ}$ ILED=55m A	315	350		nit	Note 2 Equ.PR788
Uniformity	9 Points	ΔY_9		75%	80%			Note 3
Contrast ratio		CR	$\Theta = 0^{\circ}$	700:1	1000:1	-		Note 4
Reproduction of color	White	Wx	$\Theta = 0^{\circ}$ (Center) Normal Viewing Angle	TYP. - 0.04	0.313	TYP. +0.04		Note 5
		Wy			0.329			
	Red	Rx			0.649			
		Ry			0.338			
	Green	Gx			0.323			
		Gy			0.627			
	Blue	Bx			0.155			
		By			0.056			
Color Gamut				67	72	-	%	
Response Time	Tr+Tf			-	30	35	ms	Note 6
Gamma Scale				2.0	2.2	2.4		

Note :

- Viewing angle is the angle at which the contrast ratio is greater than 10. The viewing are determined for the horizontal or 3, 9 o'clock direction and the vertical or 6, 12 o'clock direction with respect to the optical axis which is normal to the LCD surface.
- Definition of Luminance of White (Lc): Measure the luminance of gray level 255 at center point , LC=L(5), (see Figure 1 shown in Appendix 12.0).
- The White luminance uniformity on LCD surface is then expressed as : $\Delta Y = \text{Minimum Luminance of 9 points} / \text{Maximum Luminance of 9 points}$.(see Figure 1 shown in Appendix 12.0)
- Contrast measurements shall be made at viewing angle of $\theta = 0^\circ$ and at the center of the LCD surface. Luminance shall be measured with all pixels in the view field set first to white, then to the dark (black) state. (See Figure 2 shown in Appendix) Luminance Contrast Ratio (CR) is defined mathematically.

$$CR = \frac{\text{Luminance when displaying a white raster}}{\text{Luminance when displaying a black raster}}$$

- The color chromaticity coordinates specified in Table 9 shall be calculated from the spectral data measured with all pixels first in red, green, blue and white. Measurements shall be made at the center of the panel. The BLU is used by BOE.
- Response time Tg is the average time required for display transition by switching the input signal as below table and is based on Frame rate fV =60Hz to optimize. Each time in below table is defined as Figure 3 and shall be measured by switching the

Measured Response Time	Target																
	0	15	31	47	63	79	95	111	127	143	159	175	191	207	223	239	255
0																	
15																	
31																	
47																	
63																	
79																	
95																	
111																	
127																	
143																	
159																	
175																	
191																	
207																	
223																	
239																	
255																	

7. Definition of Transmittance (T%) :

Module is with white(L255) signal input

$$\text{Transmittance} = \frac{\text{Luminance of LCD Module}}{\text{Luminance of BLU}} \times 100 \%$$

7.0 MECHANICAL CHARACTERISTICS

7.1 Dimensional Requirements

Figure 3(located in Appendix 12.0) shows mechanical outlines for the model DV150X0M-N10 . Other parameters are shown in Table 13.

< Table 13. Dimensional Parameters >

Parameter	Specification	Unit
Dimensional outline	326.5(H) × 253.5(V) × 9.7(D)	mm
Weight	930	gram
Active area	304.128(H) × 228.096(V)	mm
Pixel pitch	0.297(H) × 0.297(V)	mm
Number of pixels	1024(H) × 768(V) (1 pixel = R + G + B dots)	pixels

7.2 Anti-Glare and Polarizer Hardness.

The surface of the LCD has an anti-glare coating to minimize reflection and a coating to reduce scratching.

8.0 RELIABILITY TEST

The Reliability test items and its conditions are shown in below.

< Table 14. Reliability Test Parameters >

No	Test Items	Conditions
1	High temperature storage test	Ta = 70 °C, 240 hrs
2	Low temperature storage test	Ta = -20 °C, 240 hrs
3	High temperature & high humidity storage test	Ta = 60 °C, 90%RH, 240hrs
4	High temperature operation test	Ta = 70 °C, 240 hrs
5	Low temperature operation test	Ta = -20°C, 240hrs
6	High temperature & high humidity operation test	Ta = 50 °C, 80%RH, 240hrs
7	Thermal shock	Ta = -20°C~60°C , per 30min , 100cycle , Storage
8	ESD	Contact ±8kv : Class B ; Air ±14kv : Class B
9	Packing VIB/Drop	Highway condition (0.82Grms, 1-200Hz, Random +Z/X/Y1/0.5/0.5hr) /One side fixed drop
10	VIB	10~300Hz, 1.5G, Sine, ±X, ±Y, ±Z Sweep (30 min)
11	Shock	50G,20ms,Half-sine wave, (±X,±Y,±Z), Storage

● This test condition is based on BOE Model.

9.0 PRODCUT SERIAL NUMBER



MDL ID Naming Rule:

Digit Code	1	2	3	4	5	6	7	8	9	10	11
Description	Model Code GBN		Grade	Line	Year		Month	Model Extension Code			
Digit Code	12	13	14	15	16	17	18				
Description	Serial No						Scanning does not show up, BOE factory use				

10.0 PACKING INFORMATION

BOE provides the standard shipping container for customers, unless customer specifies their packing information. The standard packing method and Barcode information are shown in below.

10.1 Packing Order

Put 1 EPE bottom into the inner box.

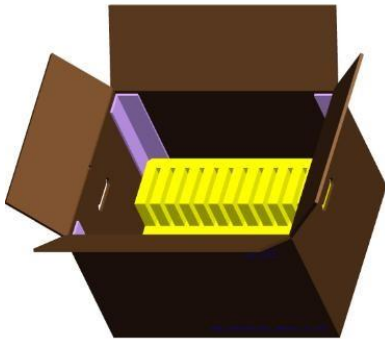

Put each module into a PE bag.

Insert 14 Pcs MDL into each box

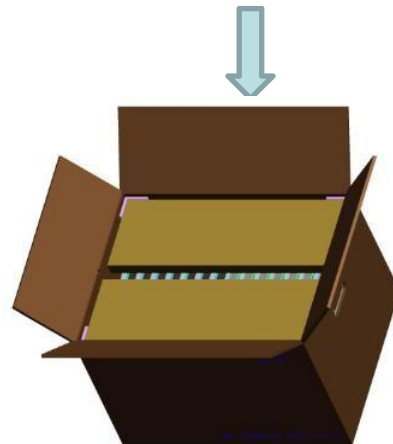
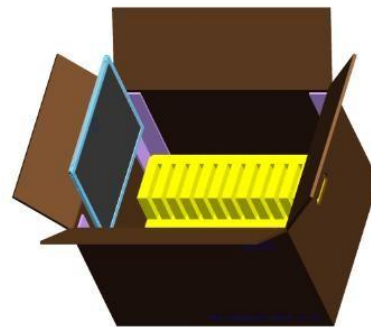

Put 1 EPE cover in and seal the box.

-Put the boxes on the Pallet
18boxes/Pallet:6boxes per layer, total 3 layers

- Place paper corners and wrap film around the boxes
- Pack with 4 packing belts,
- Pallet size is 1230*1050*1100mm, Weight:278.7KG /Pallet

20-foot general cargo container (stacked)

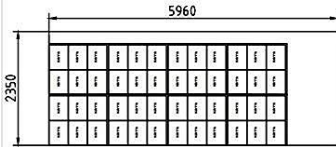

14pcs/box
3 layers per board, 6 boxes per layer
Veneer: 252pcs
Two layers of pallets, total 16 pallets
20 feet container: 4032pcs

40-foot general cargo container (stacked)

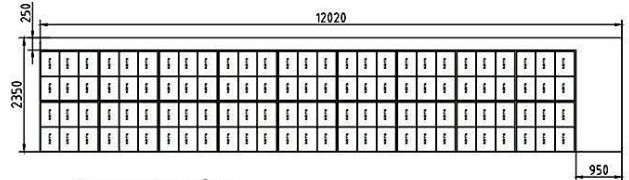

14pcs/box
3 layers per board, 6 boxes per layer
Veneer: 252pcs
Two layers of pallets, total 36 pallets
40 feet container: 9072pcs

20-foot general cargo container (single-deck)

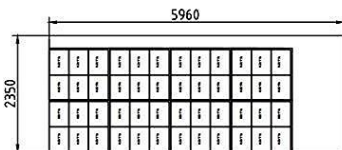

14pcs/box
3 layers per board, 6 boxes per layer
Veneer: 252pcs
One layer of pallet, total 8 pallets
20 feet container: 2016pcs

40-foot general cargo container (single-deck)

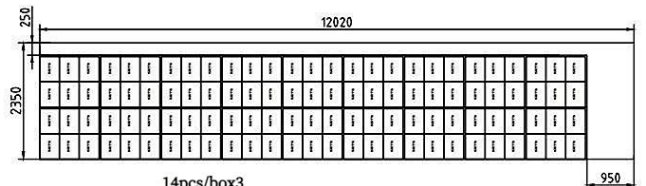

14pcs/box3
layers per board, 6 boxes per layer
Veneer: 252pcs
One layer of pallet, total 18 pallets
40 feet container: 4536pcs

10.2 Packing Note

- Box Dimension : 510mm(L)×399mm(W)×324mm(H)
- Package Quantity in one Box : 14pcs
- Weight: 14.6±0.5kg/ Box

10.3 Box Label

- Label Size : 100 mm (L) × 50 mm (W)
 - Contents
 - Model : DV150X0M-N10
 - Q`ty : Module 14 Q`ty in one box
 - Serial No. : Box Serial No.
 - Date : Packing Date

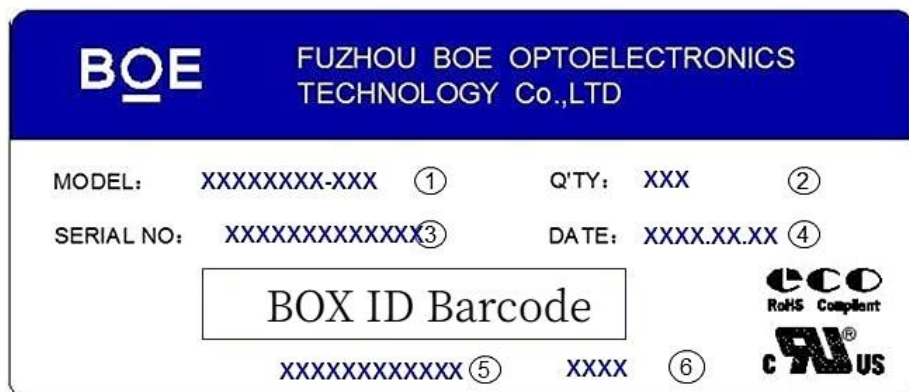

The printout, described below:

- ① FG-CODE
- ② Number of products
- ③ Box ID, The coding rules are as follows
- ④ Box Packing dates
- ⑤ Product material number (client)
- ⑥ FG-CODE last four

Digit	1	2	3	4	5	6	7						
Code	x	x	x	x	x	x	x	x	x	x	x	x	x
Des.	1. Model Code GBN 2. Grade 3. Line 4. Year(2016:16, 2017:17, ...) 5. Month(1, 2, 3, ..., 9, X, Y, Z) 6. Revision Code 7. Serial Number												

11.0 PRECAUTIONS

Please pay attention to the followings when you use this TFT LCD Module.

11.1 Mounting Precautions

- Use finger-stalls with soft gloves in order to keep display clean during the incoming inspection and assembly process.
- You must mount a module using specified mounting holes (Details refer to the drawings)
- You should consider the mounting structure so that uneven force (ex. Twisted stress, Concentrated stress) is not applied to the module. And the case on which a module is mounted should have sufficient strength so that external force is not transmitted directly to the module.
- Do not apply mechanical stress or static pressure on module; Abnormal display cause by pressing some parts of module during assembly process , do not belong to product failure, the press should be agreed by two sides.
- Determine the optimum mounting angle, refer to the viewing angle range in the specification for each model.
- Do not apply mechanical stress or static pressure on module , and avoid impact, vibration and falling.
- Acetic acid type and chlorine type materials for the cover case are not desirable because the former generates corrosive gas of attacking the polarizer at high temperature and the latter causes circuit break by electro-chemical reaction.
- Protection film for polarizer on the module should be slowly peeled off before display.
- Be careful to prevent water & chemicals contact the module surface.
- You should adopt radiation structure to satisfy the temperature specification.
- Do not touch, push or rub the exposed polarizers with glass, tweezers or anything harder than HB pencil lead. And please do not rub with dust clothes with chemical treatment. Do not touch the surface of polarizer for bare hand or greasy cloth.(Some cosmetics are detrimental to the polarizer.)
- When the surface becomes dusty, please wipe gently with absorbent cotton or other soft materials like chamois soaks with petroleum benzine. Normal-hexane & alcohol is recommended for cleaning the adhesives used to attach front / rear polarizers. Do not use acetone, toluene , because they cause chemical damage to the polarizer.
- Wipe off saliva or water drops as soon as possible. Their long time contact with polarizer causes deformations and color fading..

- This module has its circuitry PCB's on the rear side and Driver IC, should be handled carefully in order not to be stressed.
- Avoid impose stress on PCB and Driver IC during assembly process ,Do not drawing, bending, COF package & wire
- Do not disassemble the module.

11.2 Operating Precautions

- Do not connector or disconnect the cable to/from the Module at the "Power On" Condition.
- When the module is operating, do not lose CLK, ENAB signals. If any one of these signals is lost, the module would be damaged.
- Obey the supply voltage sequence. If wrong sequence is applied, the module would be damaged.
- Do not allow to adjust the adjustable resistance or switch
- The electrochemical reaction caused by DC voltage will lead to LCD module degradation, so DC drive should be avoided.
- The LCD modules use C-MOS drivers, so customers are recommended that any unused input terminal would be connected to Vdd or Vss, do not input any signals before power is turn on, and ground you body, work/assembly area, assembly equipment to protect against static electricity.
- Do not exceed the absolute maximum rating value. (supply voltage variation, input voltage variation, variation in part contents and environmental temperature, and so on) Otherwise the Module may be damaged.
- Module has high frequency circuits. Sufficient suppression to the electromagnetic interference shall be done by system manufacturers. Grounding and shielding methods may be important to minimized the interference.
- Design the length of cable to connect between the connector for back-light and the converter as shorter as possible and the shorter cable shall be connected directly , The long cable between back-light and Converter may cause the Luminance of LED to lower and need a higher startup voltage
- The cables should be as short as possible between System Board and PCB interface.
- Connectors are precision devices to transmit electrical signals, and operators should plug in parallel
- Be careful for condensation at sudden temperature change. Condensation makes damage to polarizer or electrical contacted parts. And after fading condensation, smear or spot will occur.

11.3 Electrostatic Discharge Precautions

- Avoid the use work clothing made of synthetic fibers. We recommend cotton clothing or other conductivity-treated fibers.
- Since a module is composed of electronic circuits, it is not strong to electrostatic discharge. Make certain that treatment persons are connected to ground through wrist band etc.
- Do not close to static electricity to avoid product damage.
- Do not touch interface pin directly.

11.4 Precautions for Strong Light Exposure

- Do not leave the module operation or storage in Strong light . Strong light exposure causes degradation of polarizer and color filter.

11.5 Precautions for Storage

A. Atmosphere Requirement

ITEM	UNIT	MIN	TYP	MAX
Storage Temperature	(°C)	5	25	40
Storage Humidity	(%rH)	40	50	75
Storage Life	6 months			
Storage Condition	<ul style="list-style-type: none"> • The storage room should be equipped with a dark and good ventilation facility. • Prevent products from being exposed to the direct sunlight, moisture and water. • The product need to keep away from organic solvent and corrosive gas. • Be careful for condensation at sudden temperature change. • Storage condition is guaranteed under packing conditions. 			

B. Package Requirement

- The product should be placed in a sealed polythene bag.
- Product Should be placed on the pallet, Which is away from the floor, Be cautions not to pile the product up.
- The polarizer surface should not come in contact with any other object. It is recommended that they be stored in the container in which they were shipped.
- As the original protective film, do not use the adhesive protective film to avoid change of Pol color and characteristic.

11.6 Precautions for protection film

- Remove the protective film slowly, keeping the removing direction approximate 30-degree not vertical from panel surface, If possible, under ESD control device like ion blower, and the humidity of working room should be kept over 50%RH to reduce the risk of static charge.
- People who peeled off the protection film should wear anti-static strap and grounded well.

11.7 Appropriate Condition for Commercial Display

Generally LCD modules are designed for consumer applications . Accordingly, long-term display like in Commercial Wide temperature Display application, can cause uneven display including image sticking. To optimize module's lifetime and function, several operating usages are required.

1. Normal operating condition

- Temperature: $20 \pm 15^{\circ}\text{C}$
- Operating Ambient Humidity : $55 \pm 20\%$
- Display pattern: dynamic pattern (Real display)
- Well-ventilated place is recommended to set up Commercial Display system

2. Special operating condition

a. Ambient condition

- Well-ventilated place is recommended to set up Commercial Display system.

b. Power and screen save

- Periodical power-off or screen save is needed after long-term display.

c. As the low temperature, the response time is greatly delayed. As the high temperatures (higher than the operating temperature) the LCD module may turn black screen. The above phenomenon cannot explain the failure of the display. When the temperature returns to the normal operating temperature, the LCD module will return to normal display.

d. When expose to drastic fluctuation of temperature (hot to cold or cold to hot) ,the LCD module may be affected; Specifically, drastic temperature fluctuation from cold to hot ,produces dew on the LCD module 's surface which may affect the operation of the polarizer and LCD module

e. Do not exceed the absolute maximum rating value. (supply voltage variation, input voltage variation, variation in part contents and environmental temperature, and so on) Otherwise the Module may be damaged.

f. Products exposed to low temperature environment for a long time, need to carry out necessary protection , low temperature environment is usually refrigerators , vending machine Etc...

g. Long time and large angle forward use or unconventional use , It is strongly recommended to contact BOE for filed application engineering advice

h. Product reliability and functions are only guaranteed when the product is used under right operation usages. If product will be used in extreme conditions such as high temperature, high humidity, high altitude, special display images, running time, long time operation, outdoor operation, etc. It is strongly recommended to contact BOE for filed application engineering advice. Otherwise, its reliability and function may not be guaranteed.

3. Operating usages to protect against image sticking due to long-term static display.

a. Static information display recommended to use with moving image.

- Cycling display between 5 minutes' information(static) display and 10 seconds' moving image.

b. Background and character (image) color change

- Use different colors for background and character, respectively.

- Change colors themselves periodically.

c. Avoid combination of background and character with large different luminance.

1) Abnormal condition just means conditions except normal condition.

2) Black image or moving image is strongly recommended as a screen save

4. Lifetime in this spec. is guaranteed only when Commercial Display is used according to operating usages.

11.8 Other Precautions

A. LC Leak

- If the liquid crystal material leaks from the panel, it is recommended to wash the LC with acetone or ethanol and then burn it.
- If the liquid crystal material leaks from the panel, it should be kept away from the eyes or mouth. In case of contact with hands, skin or clothes, it has to be washed away thoroughly with soap.
- If LC in mouth, mouth need to be washed, drink plenty of water to induce vomiting and follow medical advice.
- If LC touch eyes, eyes need to be washed with running water at least 15 minutes.

B. Rework

- When returning the module for repair or etc., Please pack the module not to be broken. We recommend to use the original shipping packages.

12.0 APPENDIX

< Figure 1.Uniformity Measurement Locations (9 points)>

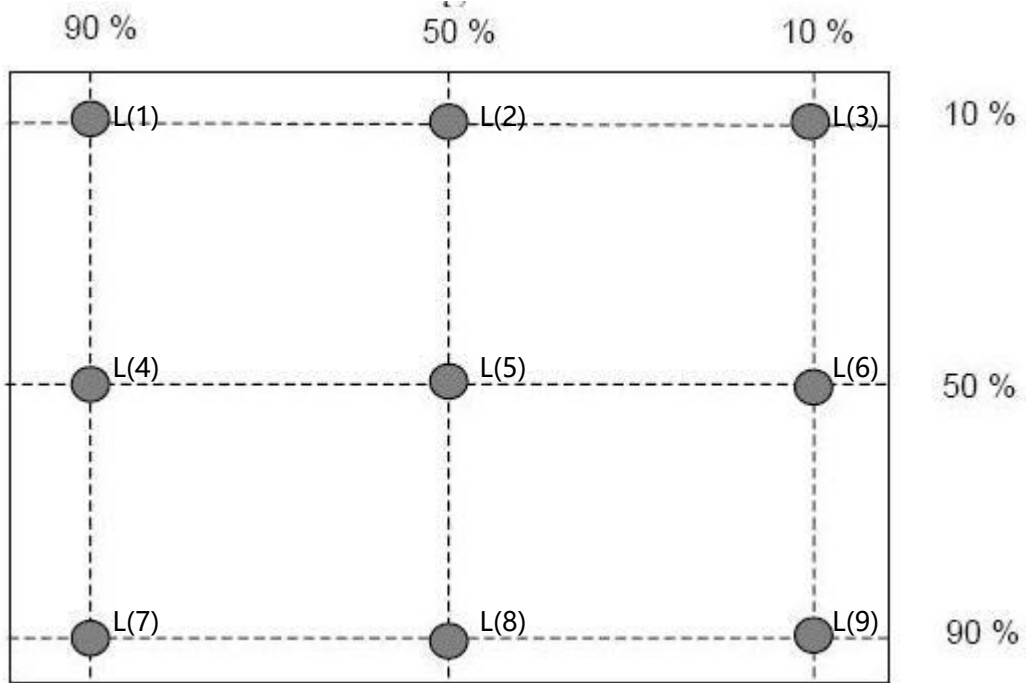

The White luminance uniformity on LCD surface is then expressed as : $\Delta Y9 = \text{Minimum Luminance of five points} / \text{Maximum Luminance of 9 points}$

12.0 APPENDIX

< Figure 2. Measurement Set Up >

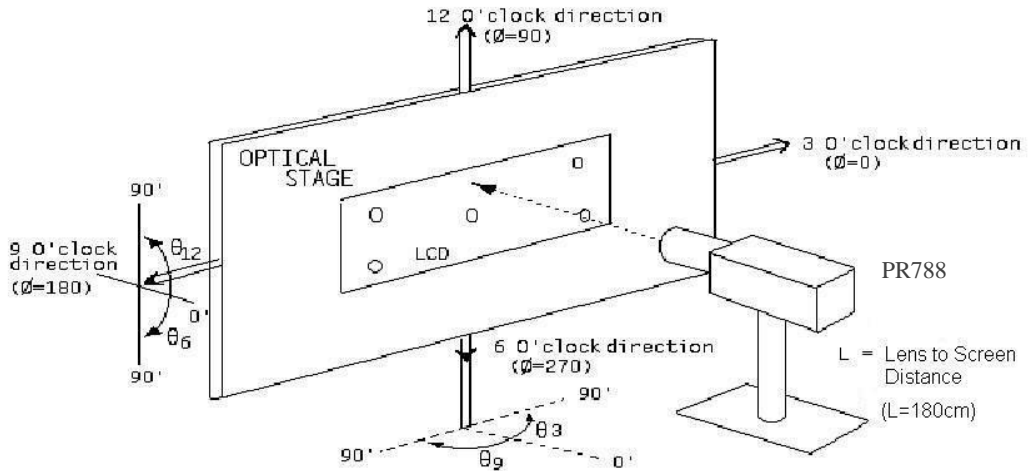

< Figure 3. Response Time Testing >

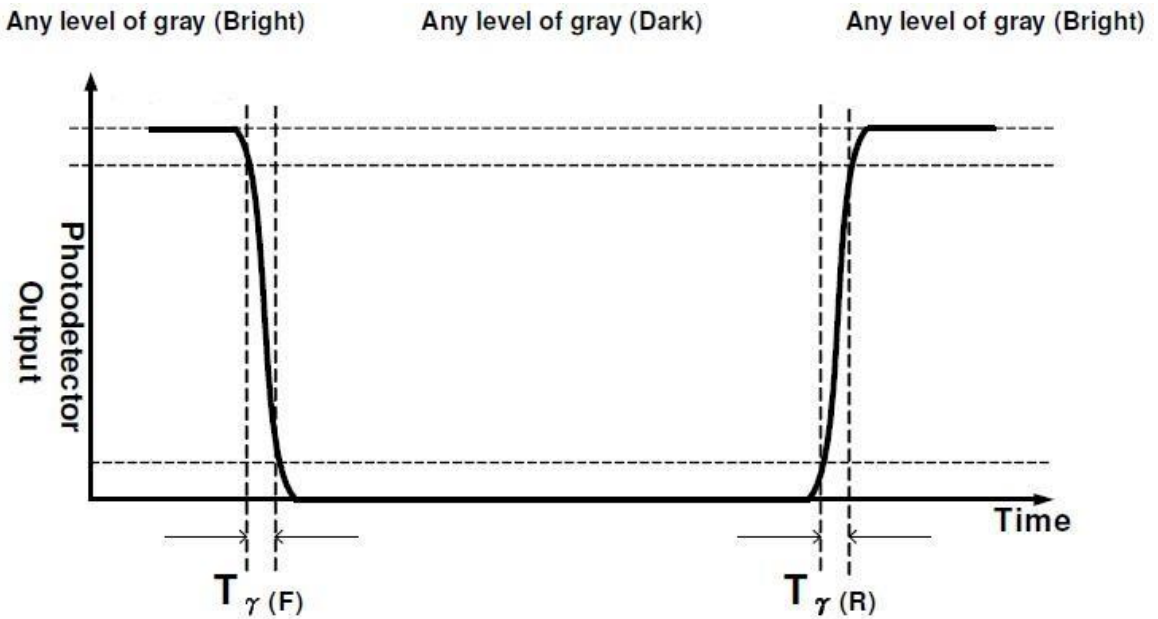

12.0 APPENDIX

< Figure 3.TFT-LCD Module Outline Dimensions (Front View) >

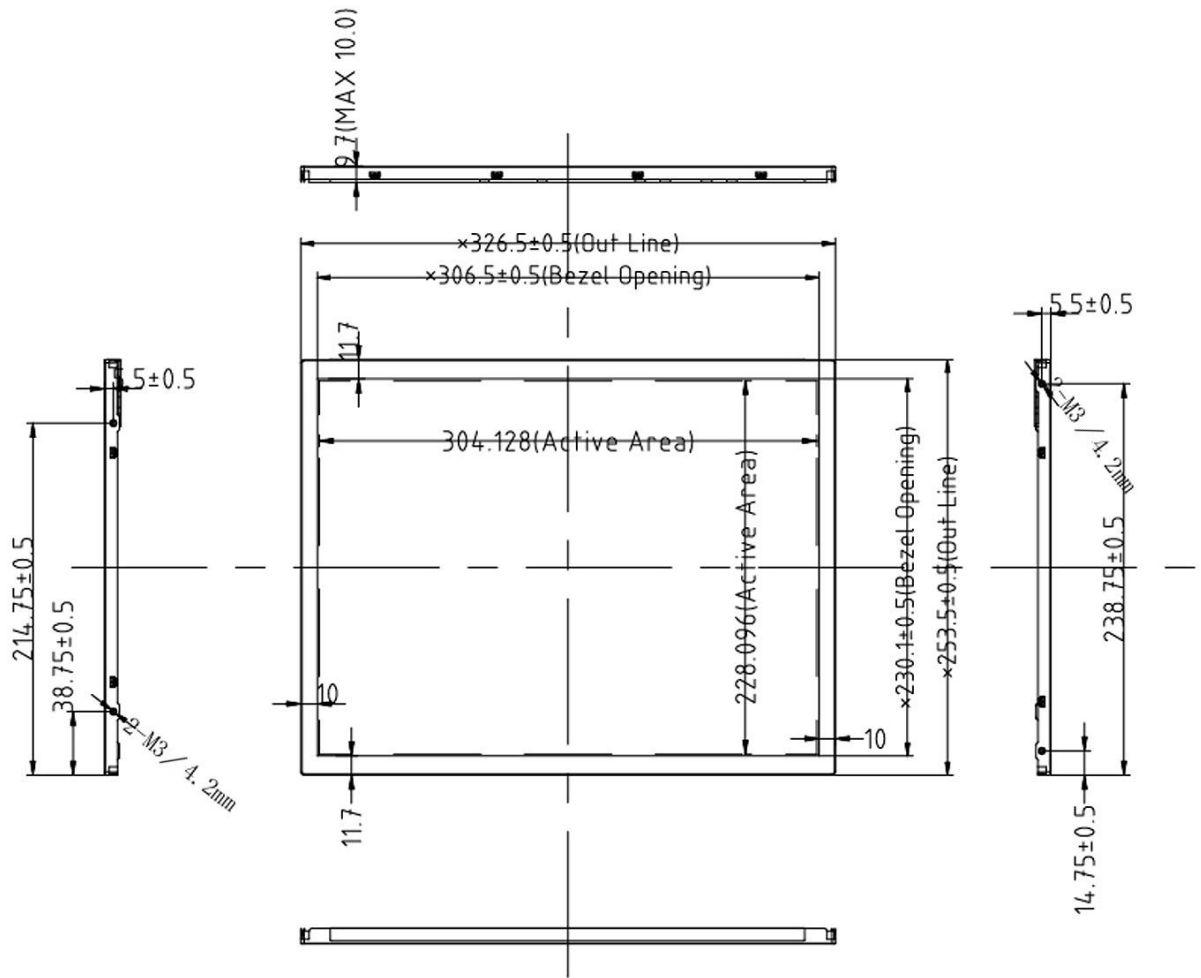

12.0 APPENDIX

< Figure 4.TFT-LCD Module Outline Dimensions (Rear View) >

